

HARMONY[®]

赫梅尼 CE

H.2022

智能真空搬运设备生产商及服务商

Intelligent vacuum lift equipment manufacturer and service provider

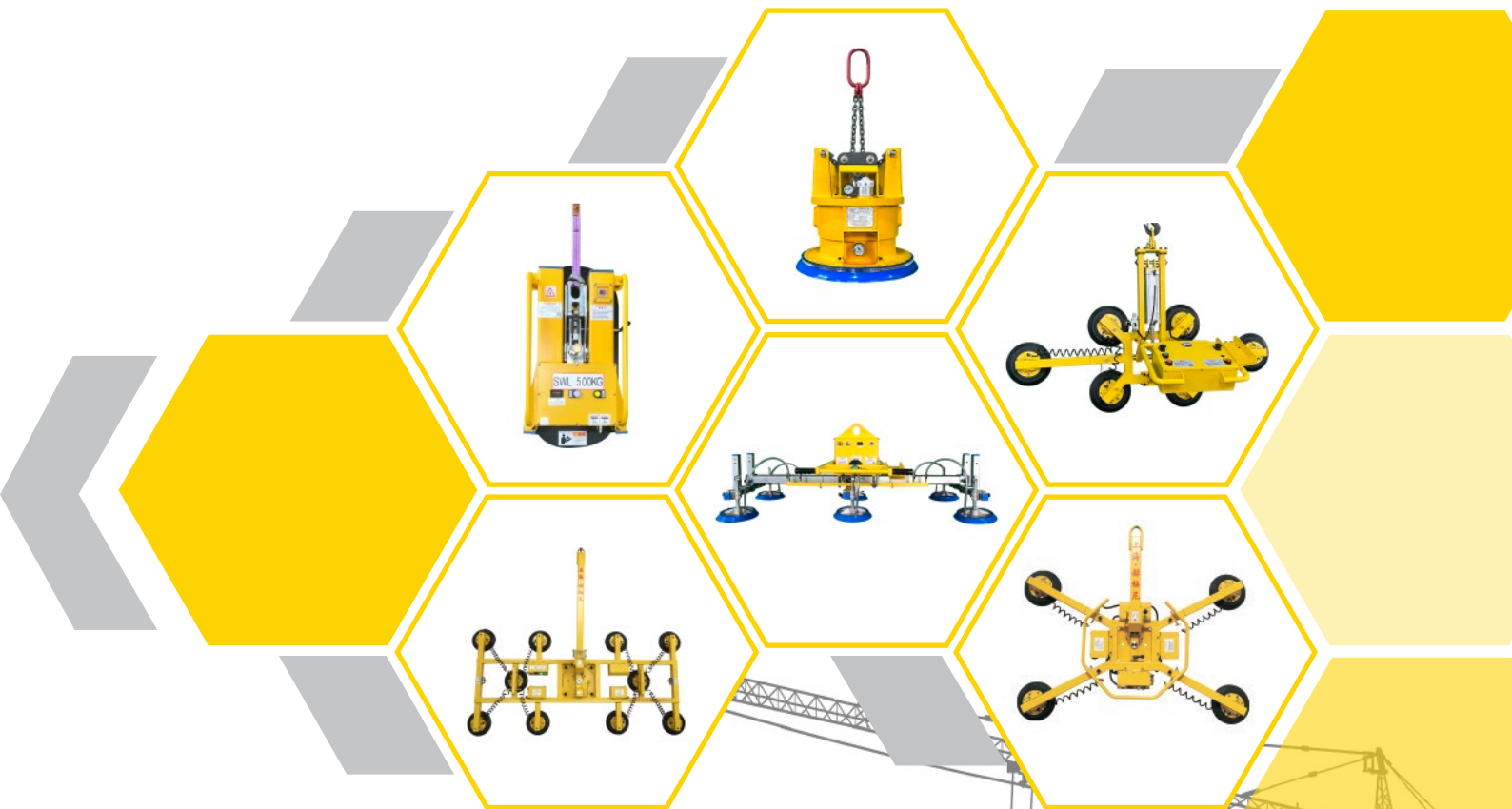

中国·上海
Shanghai·China





公司简介 COMPANY PROFILE

上海赫梅尼自动化设备有限公司是一家专业生产真空吸吊设备的制造商。公司以工厂自动化和真空智能搬运为方向，面向机械加工、玻璃幕墙、玻璃深加工、食品加工、铝制品、激光加工、汽车制造、包装物流、石材加工、太阳能等领域，提供设计、规划、制造、安装、培训和售后等一站式服务。

Shanghai Harmony automation equipment Co., Ltd. is a professional manufacturer specializing in the production of vacuum suction crane equipment. The company is oriented to factory automation and vacuum intelligent handling, and provides one-stop service of design, planning, manufacturing, installation, training and after-sales service for mechanical processing, glass curtain walls, glass deep processing, food processing, aluminum products, laser processing, automobile manufacturing, packaging logistics, stone processing, solar energy and other fields.



企业文化 ENTERPRISE CULTURE

核心价值

以客户需求为导向、以产品质量为基础、以技术创新为核心

品牌愿景

打造真空搬运设备的代表性企业

企业初心

为客户提供优质的真空搬运设备

工作精神

自律、严谨、争先、关爱

经营理念

为客户创造价值，为企业增添财富

管理哲学

制度为基，以人为本，讲究实效，雷厉风行



公司特色

COMPANY CHARACTERISTICS

领先的自主品牌

Leading independent brand

公司成立于2012年，总部位于中国上海。经过10年的发展，依托上海优良的区域优势和专业研发团队，自主品牌“赫梅尼系列产品”在行业内已经具有一定的知名度和美誉度，并不断向行业标杆迈进。我们的产品在欧洲、北美、南美、澳洲、东亚、南亚、西亚、东南亚等多个地区具有相当的影响力。

The company was founded in 2012 and is headquartered in Shanghai, China. After 10 years of development, relying on Shanghai's excellent regional advantages and professional R&D team, the independent brand "Harmony Series" has already gained a certain degree of popularity and reputation in the industry, and is constantly striding forward to the industry benchmark. Our products have considerable influence in Europe, North America, South America, Australia, East Asia, South Asia, West Asia, Southeast Asia and other regions.

强大的用户规模

Strong user scale

公司产品销往美国、德国、法国、加拿大、英国、澳大利亚、以色列、西班牙、韩国、智利、塞浦路斯、印度、巴勒斯坦、柬埔寨、菲律宾等多个国家，得到众多国家市场的认可。

The company's products are sold to the United States, Germany, France, Canada, the United Kingdom, Australia, Israel, Spain, South Korea, Chile, Cyprus, India, Palestine, Cambodia, the Philippines and other countries, and have been recognized by many national markets.

专业的服务团队

Professional service team

拥有一支具有工匠精神和创新精神的专业优秀的设计工程师、产品工程师、销售工程师，根据客户的图纸和规格进行修改和设计，实现专业化定制，为客户提供高质量的产品和高性价比的机器，持续以优质的服务提高客户满意度。

Our company has a team of professional and excellent design engineers, product engineers, and sales engineers with the spirit of craftsmanship and innovation, who modify and design according to customers' drawings and specifications, realize professional customization, provide customers with high-quality products and cost-effective machines and continue to improve customer satisfaction with high quality service.















专业的解决方案

Professional solution

长期以来，我们一直秉承“质量是企业永恒的主题”的价值观，并以为客户提供最优解决方案为指导准则，推出了一系列具有独特竞争优势的工业智能搬运设备及真空技术的完整解决方案。

For a long time, we have been adhering to the value of "Quality is the forever theme of enterprise", and taking the best solutions for customers as the guiding principle, we have launched a series of total solution for industrial intelligent handling equipment and vacuum technology with unique competitive advantages.



	无动力真空吸吊设备 HP-WDL01-02 Unpowered vacuum crane HP-WDL
	板材小型吸吊设备 HP-BS03-04 Board small-scale suction crane equipment HP-BS
	板材大型吸吊设备 HP-BL05-06 Board large-scale suction crane equipment HP-BL
	玻璃幕墙小型吸吊设备 HP-GX07-10 Glass curtain wall small-scale suction crane equipment HP-GX
	玻璃幕墙大型吸吊设备 HP-GH11-12 Glass curtain wall large-scale suction crane equipment HP-GH
	玻璃深加工小型吸吊设备 HP-GF13-14 Small-scale of lifting equipment of glass deep processing HP-GF
	玻璃深加工大型吸吊设备 HP-GHQ15-16 Large-scale of lifting equipment of glass deep processing HP-GHQ
	弯弧玻璃吸吊设备 HP-GA17-18 Arc glass suction crane equipment HP-GA
	电动翻转型吸吊设备 HP-DF19-20 Electric flip suction crane equipment HP-DF
	卷材与定制吸吊设备 HP-CC21 Coil and customized suction crane equipment HP-CC
	玻璃幕墙小型吸吊设备 HP-GI22 Glass curtain wall small-scale suction crane equipment HP-GI
	配套设备 (立柱悬臂吊) HP-LZ23 Supporting equipment (jib crane) HP-LZ
	配套设备 (墙壁吊) HP-QB24 Supporting equipment (jib crane) HP-QB
	配套设备 (桥式导轨) HP-QS25 Supporting equipment (overhead kbc crane) HP-QS

无动力真空吸吊设备 HP-WDL Unpowered vacuum crane HP-WDL

- 无需安装，吸盘吊环直接与行车吊钩连接即可
No need to install, the sucker ring can be directly connected with the crane hook.
- 依靠链条的松弛与张紧来控制真空产生与释放，通过真空控制阀来完成吸取，释放操作
Rely on the slack and tension of the chain to control the vacuum generation and release, and complete the suction and release operations through the vacuum control valve.
- 无需任何控制按钮，无需任何外部动力，不受断电或电压不足的影响
No need for any control buttons, no need for any external power, not affected by power failure or insufficient voltage.
- 不需要外接电线或者气管，设备可以移动至任何一个有起重设备的地方工作，且设备可以自由360度旋转
Since there is no need for external wires or air pipes, the equipment can be moved to any place with lifting equipment to work, and the equipment can rotate freely 360 degrees.
- 只有当工件被放下，链条完全松弛状态下，才能释放工件，不会存在误操作，所以安全性极高
Only when the workpiece is put down and the chain is completely slack, the workpiece can be released. There will be no misoperation, so the safety is extremely high.



产品名称及型号 Product&Model	安全载重 Safety Loading	外型尺寸(mm) Size	吸盘直径 (mm) Sucker Diameter	吸盘个数 Sucker Number	电源系统 Power System	控制方式 Control Mode	设备自重 Dead Load
HP-WDL800-1S	800KG	Ø450X450	Ø450	1个	无动力	自动	90KG
HP-WDL1000-2S	1000KG	1500X450	Ø450	2个	无动力	自动	150KG
HP-WDL800-4S	800KG	1800X800	Ø300	4个	无动力	自动	160KG
HP-WDL1000-6S	1000KG	2000X800	Ø300	6个	无动力	自动	180KG



铝板水平搬运
单头无动力真空吸吊设备 HP-WDL800-1S (800KG)

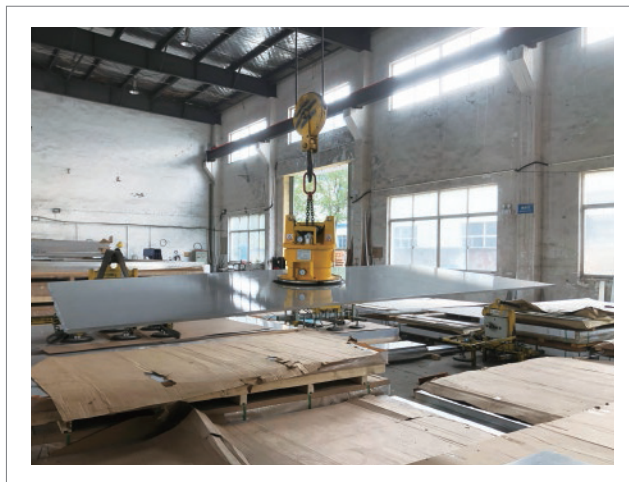

铝板水平搬运
单头无动力真空吸吊设备 HP-WDL800-1S (800KG)



铝板水平搬运
单头无动力真空吸吊设备 HP-WDL800-1S (800KG)



铝切机上料
单头无动力真空吸吊设备 HP-WDL800-1S (800KG)



铝切机上料
单头无动力真空吸吊设备 HP-WDL800-1S (800KG)



碳钢板水平搬运
单头无动力真空吸吊设备 HP-WDL800-1S (800KG)

板材小型吸吊设备 HP-BS Board small-scale suction crane equipment HP-BS

- HP-BS系列设备广泛应用于各种板材的无损搬运，如不锈钢板，铝板，钛板，复合板等
HP-BS series of equipment are widely used for non-destructive handling of various plates, including corrosion resistant plates, aluminium plates, titanium plates, composite panels, etc.
- 同样广泛应用于激光切割机，等离子切割机，水刀切割机，数控冲床等
They are also widely used for laser cutting machine, plasma cutting machine, water-jet cutting machine, numerical control press, etc.
- 吸盘座采用铸铝材质，一次性高压压铸成型，质量轻，强度高，吸盘胶皮可拆卸，更换方便且环保，性价比更高
The equipment suction cup made of cast aluminum with one-time high-pressure die-casting molding, have characteristics of light weight, high strength, detachable suction cup rubber, easy to replace, environmentally friendly and have high cost-effective.
- 全新纯气动系统，无需接电，无需充电，气动升降，气动吸附，经济实用
Brand-new pure pneumatic system, no need to connect electricity, no charge, pneumatic lifting, pneumatic adsorption, economical and practical.
- 吸盘位置可调节以满足不同板材尺寸的变化
Sucker position can be adjusted to meet dimensional change of different plates.



产品名称及型号 Product&Model	安全载重 Safety Loading	外型尺寸(mm) Size	吸盘直径 (mm) Sucker Diameter	吸盘个数 Sucker Number	电源系统 Power System	控制方式 Control Mode	设备自重 Dead Load
HP-BSJ500-6S	500kg	2000x800	Ø230	6个	380V	手动/遥控	100kg
HP-BSZ500-6S					DC12V		
HP-BSQ500-6S					气动		
HP-BSJ1000-6S	1000kg	2000x800	Ø230	6个	380V	手动/遥控	110kg
HP-BSZ1000-6S					DC12V		
HP-BSJ800-8S	800kg	2800x800	Ø230	8个	380V	手动/遥控	130kg
HP-BSZ800-8S					DC12V		
HP-BSJ1500-8S	1500kg	2800x800	Ø300	8个	380V	手动/遥控	140kg
HP-BSZ1500-8S					DC12V		
HP-BSJ1000-10S	1000kg	(1m+3m+1m)x1000	Ø230	10个	380V	手动/遥控	210kg
HP-BSZ1000-10S					DC12V		
HP-BSJ2000-10S	2000kg	(1m+3m+1m)x1000	Ø300	10个	380V	手动/遥控	250kg
HP-BSZ2000-10S					DC12V		
HP-BSJ2500-12S	2500kg	(1m+3m+1m)x1000	Ø300	12个	380V	手动/遥控	280kg
HP-BSZ2500-12S					DC12V		



不锈钢板水平搬运
交流六爪吸吊设备 HP-BSJ1000-6S (1000KG)



碳钢板水平搬运
直流六爪吸吊设备 HP-BSZ1000-6S (1000KG)



不锈钢板水平搬运
气动六爪吸吊设备 HP-BSQ500-6S (500KG)



碳钢板水平搬运
交流十爪吸吊设备 HP-BSJ2000-10S (2000KG)



不锈钢板水平搬运
直流十爪吸吊设备 HP-BSZ2000-10S (2000KG)



碳钢板水平搬运(长续航版)
直流十爪吸吊设备 HP-BSZ2000-10S (2000KG)

板材大型吸吊设备 HP-BL Board large-scale suction crane equipment HP-BL

- HP-BL系列设备广泛应用于各种大型板材的无损搬运
HP-BL series of equipment are widely used for non-destructive handling of various large panels.
- 采用德国贝克大流量真空泵，超大流量,吸力强劲,安全可靠
Adopting German Becker large-flow vacuum pump with extremely large flow and strong suction, which is safe and reliable.
- 大容积蓄能器，防止意外断电后，工件仍然可以保持吸附状态5-30分钟不掉落
The large-capacity accumulator prevents the workpiece from remaining in the sucker position for 5-30 minutes after the accidental power failure.
- 真空泄露报警-确保设备在标准真空度(80%或90%)之上安全工作
Vacuum leak alarm - ensure that the equipment works safely above the standard vacuum (80% or 90%).
- 采用高强度耐磨型丁腈橡胶，超长质保十八个月
Adopting high-strength wear-resistant acrylonitrile-butadiene rubber with long quality guarantee period for 18 months.
- 吸盘位置可调节以满足不同板材尺寸的变化
Sucker position can be adjusted to meet size changes of different plates.



产品名称及型号 Product&Model	安全载重 Safety Loading	外型尺寸(mm) Size	吸盘直径 (mm) Sucker Diameter	吸盘个数 Sucker Number	电源系统 Power System	控制方式 Control Mode	设备自重 Dead Load
HP-BLZ3000-16S	3000kg	6000x1200	Ø300	16个	DC12V	手动/遥控	600kg
HP-BLJ3000-16S	3000kg	6000x1200	Ø300	16个	380V	手动/遥控	600kg
HP-BLJ5000-10S	5000kg	6000x1200	Ø450	10个	380V	手动/遥控	1000kg
HP-BLJ6000-12S	6000kg	8000x1200	Ø450	12个	380V	手动/遥控	1400kg
HP-BLJ8000-16S	8000kg	10000x1500	Ø450	16个	380V	手动/遥控	1800kg
HP-BLJ8000-8S	8000kg	10000x1500	850x450	8个	380V	手动/遥控	2000kg
HP-BLJ10000-10S	10T	12000x2000	850x450	10个	380V	手动/遥控	2800kg
HP-BLJ15000-16S	15T	15000x2000	850x450	16个	380V	手动/遥控	4000kg
HP-BLJ20000-20S	20T	18000x2000	850x450	20个	380V	手动/遥控	5500kg



碳钢板水平搬运 (双系统)
直流二十爪吸吊设备 HP-BLZ2000-20S (2000KG)

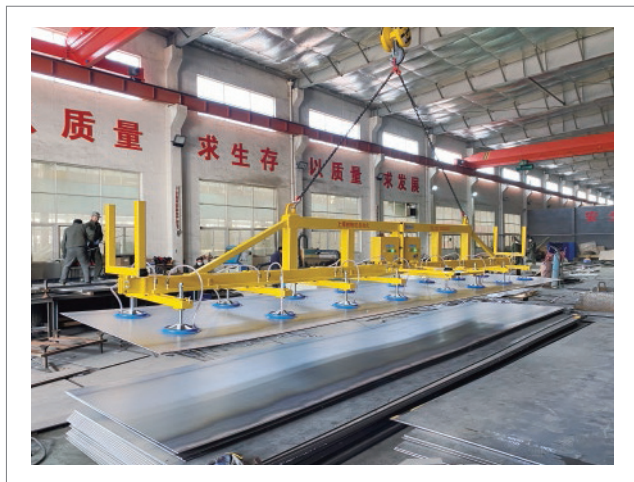

碳钢板水平搬运 (双系统)
直流十六爪吸吊设备 HP-BLZ3000-16S (3000KG)



碳钢板水平搬运 (双系统)
直流十六爪吸吊设备 HP-BLZ3000-16S (3000KG)



碳钢板水平搬运
交流八爪吸吊设备 HP-BLJ8000-8S (8000KG)



不锈钢板水平搬运
交流八爪吸吊设备 HP-BLJ8000-8S (8000KG)



不锈钢板水平搬运
交流十爪吸吊设备 HP-BLJ10000-10S (10T)

玻璃幕墙小型吸吊设备 HP-GX Glass curtain wall small-scale suction crane equipment HP-GX

- HP-GX系列设备广泛应用于玻璃搬运及玻璃幕墙安装
HP-GX series of equipment are widely used in glass transition and glass curtain wall installation.
- 采用直流真空泵+直流电池, 在使用过程中, 无需另外接气源或电源
DC vacuum pump + DC battery are adopted; When using, there is no need to connect other air source or power source.
- 数显式真空压力开关及电池电量表, 能更清楚的监测设备安全运转
Digital display vacuum pressure switch and battery charge indicator, which can monitor safe operation of equipment more clearly.
- 设备自带真空补压系统, 可保证玻璃在搬运过程中整个真空系统维持在一个相对恒定的安全压力值
With vacuum pressure charging system, equipment can ensure the whole vacuum system within a relatively constant safe pressure value during transition.

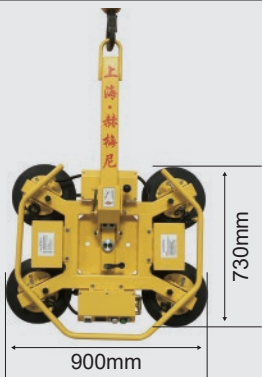
	产品名称及型号 Product & Model	X型四爪手翻手旋吸吊设备 X-type four-jaw vacuum lifter manual rotating/tilting HP-GX400-4S
	外型尺寸 Size	900x730x240(mm)
	电源系统 Power System	DC12V
	安全载重量 Safety Loading	400KG
	充电器 Charger	AC220V
	功能 Function	90度手动翻转, 360度手动旋转 Flip 90 degrees(Manual) Rotate 360 degrees(Manual)

该设备具备以下4种组装方式
The equipment possesses the following four assembly methods

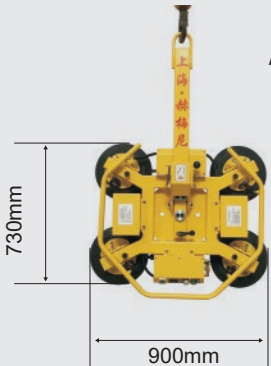
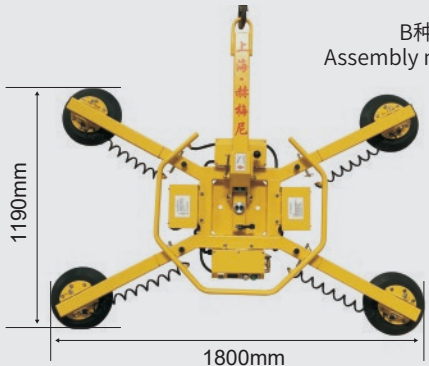
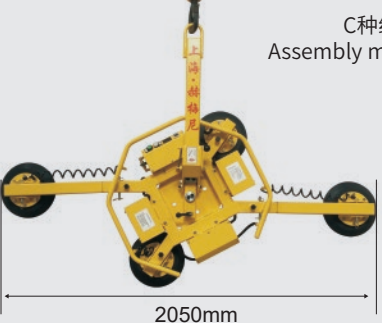
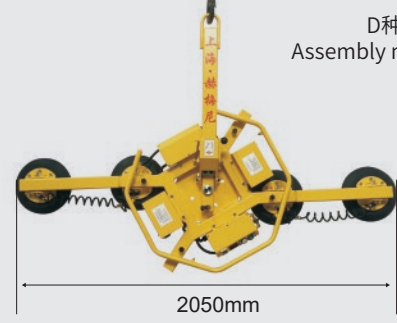
<p>A种组装方式 Assembly method A</p> 	<p>B种组装方式 Assembly method B</p> 
<p>C种组装方式 Assembly method C</p> 	<p>D种组装方式 Assembly method D</p> 



沈阳远大铝业工程有限公司-工程应用

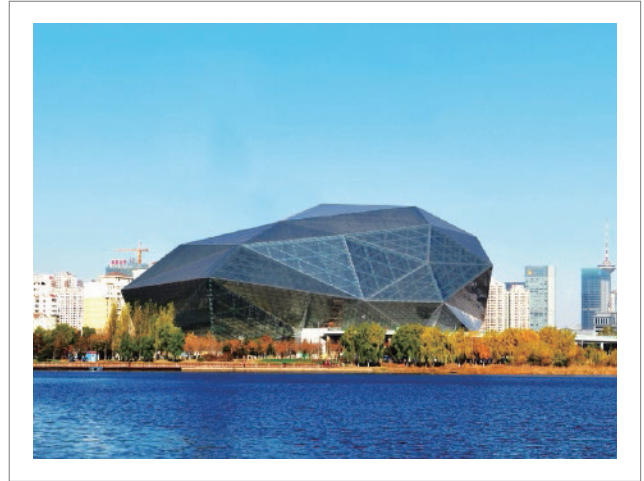

沈阳文化艺术中心



上海通用金属结构工程有限公司-工程应用



南京牛首山佛顶宫



香港鉅城工程有限公司-工程应用



港珠澳跨海大桥(香港旅检中心大楼)

玻璃幕墙小型吸吊设备 HP-GX (加强型)

Glass curtain wall small-scale suction crane equipment HP-GX (Enhanced)

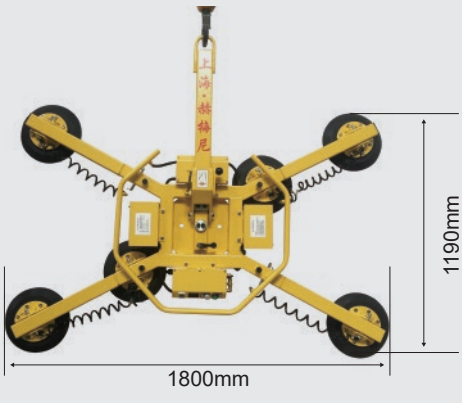
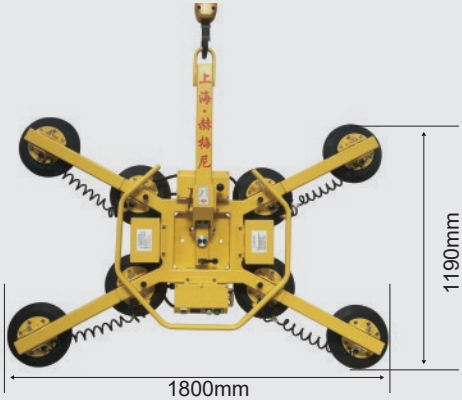
	产品名称及型号 Product & Model	X型六爪手翻手旋吸吊设备 X-type six-jaw vacuum lifter manual rotating/tilting HP-GX500-6S
	外型尺寸 Size	1800x1190x240(mm)
	电源系统 Power System	DC12V
	安全载重量 Safety Loading	500KG
	充电器 Charger	AC220V
功能 Function	90度手动翻转, 360度手动旋转 Flip 90 degrees(Manual) Rotate 360 degrees(Manual)	
	产品名称及型号 Product & Model	X型八爪手翻手旋吸吊设备 X-type eight-jaw vacuum lifter manual rotating/tilting HP-GX600-8S
	外型尺寸 Size	1800x1190x240(mm)
	电源系统 Power System	DC12V
	安全载重量 Safety Loading	600KG
	充电器 Charger	AC220V
功能 Function	90度手动翻转, 360度手动旋转 Flip 90 degrees(Manual) Rotate 360 degrees(Manual)	

应用案例 Applications



时代广场玻璃幕墙安装
直流八爪吸吊设备 HP-GX600-8S (600KG)



永旺梦乐城玻璃幕墙安装
直流八爪吸吊设备 HP-GX600-8S (600KG)

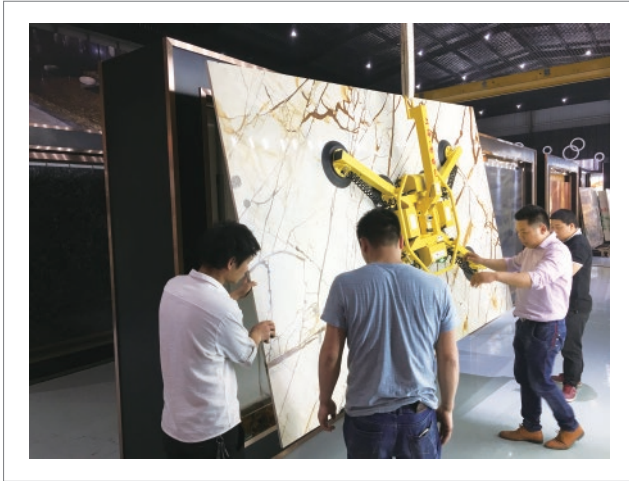

大理石室内搬运
直流八爪吸吊设备 HP-GX600-8S (600KG)

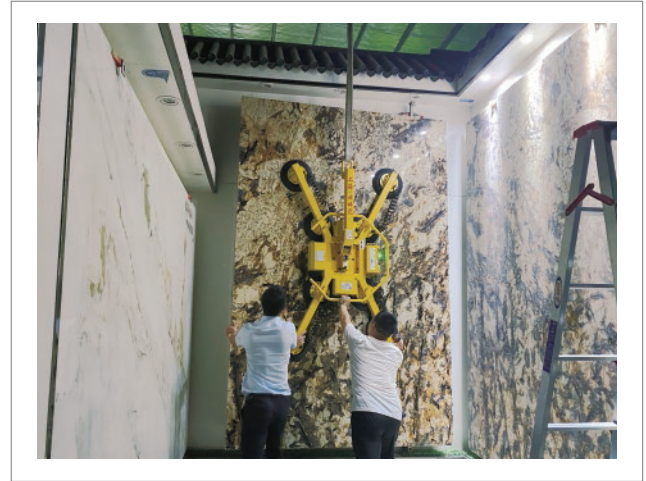

大理石室内搬运
直流八爪吸吊设备 HP-GX600-8S (600KG)

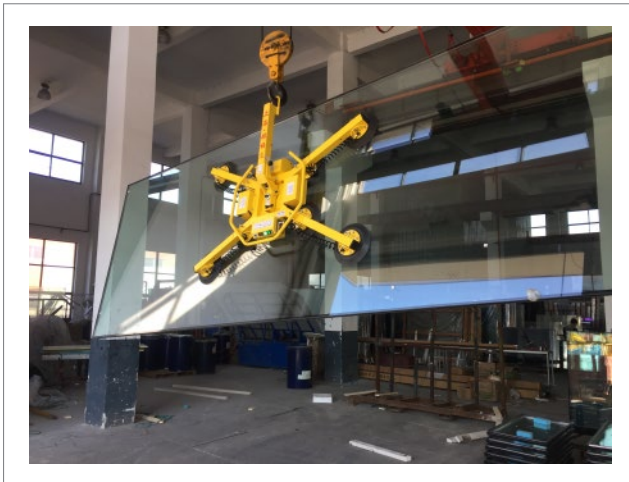

中空夹胶玻璃室内搬运
直流八爪吸吊设备 HP-GX600-8S (600KG)



中空夹胶玻璃室内装箱搬运
直流八爪吸吊设备 HP-GX600-8S (600KG)



室外玻璃幕墙安装
直流八爪吸吊设备 HP-GX600-8S (600KG)



莫干山名宿玻璃幕墙安装
直流八爪吸吊设备 HP-GX600-8S (600KG)

玻璃幕墙大型吸吊设备 HP-GH Glass curtain wall large-scale suction crane equipment HP-GH

- HP-GH系列设备广泛应用于玻璃搬运及玻璃幕墙安装
HP-GH series of equipment are widely used in glass transition and glass curtain wall installation.
- 采用直流真空泵+直流电池，在使用过程中，无需另外接气源或电源
DC vacuum pump + DC battery are adopted; When using, there is no need to connect other air source or power source.
- 数显式真空压力开关及电池电量表，能更清楚的监测设备安全运转
Digital display vacuum pressure switch and battery charge indicator, which can monitor safe operation of equipment more clearly.
- 设备自带真空补压系统，可保证玻璃在搬运过程中整个真空系统维持在一个相对恒定的安全压力值
With vacuum pressure charging system, equipment can ensure the whole vacuum system within a relatively constant safe pressure value during transition.

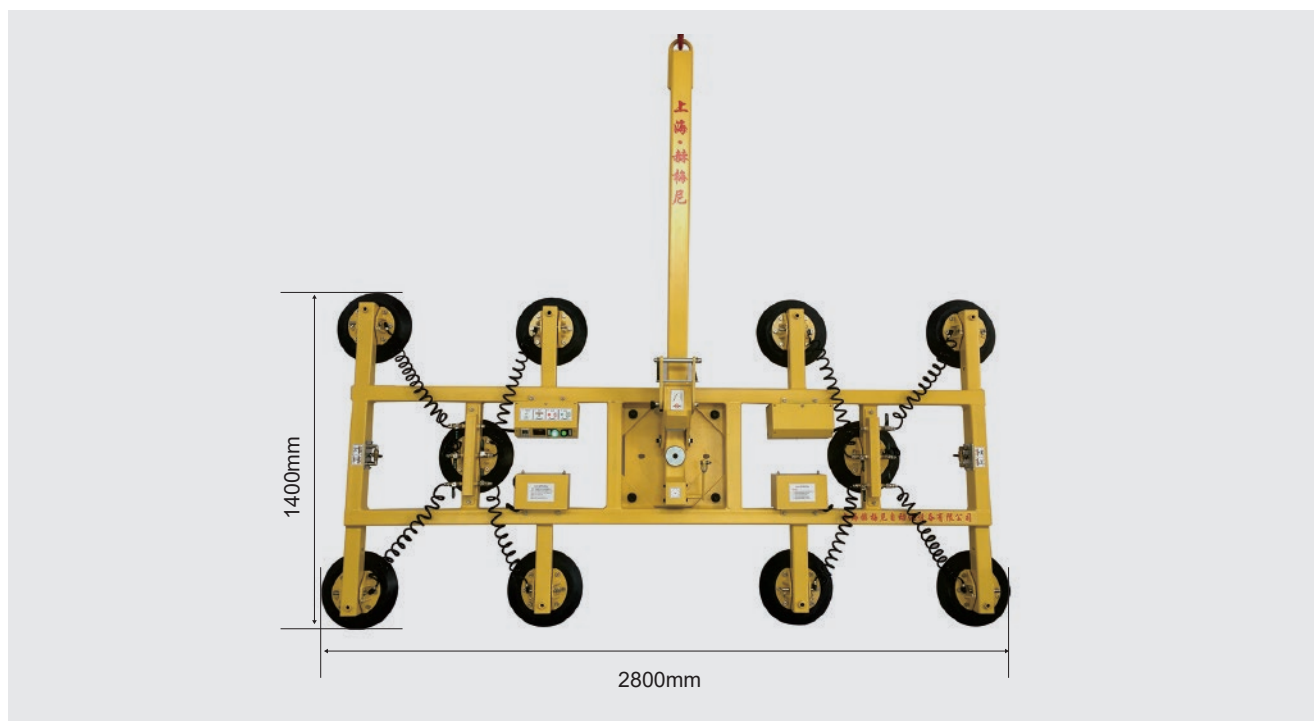

产品名称及型号 Product&Model	安全载重 Safety Loading	外型尺寸(mm) Size	吸盘直径 (mm) Sucker Diameter	吸盘个数 Sucker Number	电源系统 Power System	控制方式 Control Mode	功能 Function
HP-GH800-8S	800kg	2800x1400x220	∅300	8个	DC12V	手动/遥控	手动360度旋转以及90度翻转 Rotating 360 Degree (Manual) and Tilting 90 degree (Manual)
HP-GH1000-10S	1000kg	2800x1400x220	∅300	10个	DC12V	手动/遥控	
HP-GH1200-12S	1200kg	(1000+2800+1000)x1400x220	∅300	12个	DC12V	手动/遥控	
HP-GH1500-16S	1500kg	(1000+3000+1000)x1400x400	∅300	16个	DC12V	手动/遥控	
HP-GH2000-20S	2000kg	(1500+3600+1500)x1400x400	∅300	20个	DC12V	手动/遥控	
HP-GH3000-30S	3000kg	(1500+3600+1500)x1400x400	∅300	30个	DC12V	手动/遥控	
HP-GH5000-50S	5000kg	(1500+5000+1500)x1400x600	∅300	50个	DC12V	遥控	液压360度旋转以及90度翻转

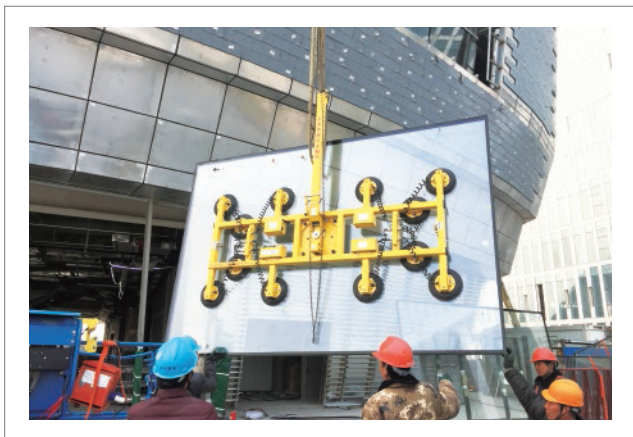

上海凯迪拉克中心幕墙安装
直流十二爪吸吊设备 HP-GH1200-12S (1200KG)



博世中国厂房幕墙安装
直流十爪吸吊设备 HP-GH1000-10S (1000KG)



天空之城玻璃栈道安装
直流二十爪吸吊设备 HP-GH2000-20S (2000KG)



淮海路古驰店幕墙安装(双系统)
直流三十爪吸吊设备 HP-GH3000-30S (3000KG)



杭州银泰购物中心幕墙安装
直流十爪吸吊设备 HP-GH1000-10S (1000KG)



室外大型玻璃幕墙安装(双系统)
直流四十爪吸吊设备 HP-GH4000-40S (4000KG)

玻璃深加工小型吸吊设备 HP-GF Small-scale of lifting equipment of glass deep processing HP-GF

- HP-GF系列设备广泛应用于各种原片玻璃，中空玻璃，夹胶玻璃，钢化玻璃，太阳能光伏玻璃的吊装
HP-GF series equipment is widely used in lifting Sheet Glass, Hollow Glass, Laminated Glass, Tempered Glass and Solar Photovoltaic Glass.
- 采用日本进口SMC真空发生器，体积小，流量大，故障率低
The equipment adopts SMC Vacuum generator imported from Japan, with small size, large flow and low failure rate.
- 采用日本进口SMC双色压力显示表，能更为清楚地检测设备安全运转
The equipment also adopts SMC bi-color pressure gauge, can detect the safe operation of equipment more clearly.
- 该设备升降，翻转，旋转，均采用日本进口SMC品牌气缸，性能稳定，品质卓越
The lifting, turning, and rotating equipment adopts Japanese imported SMC brand cylinders with stable performance and excellent quality.

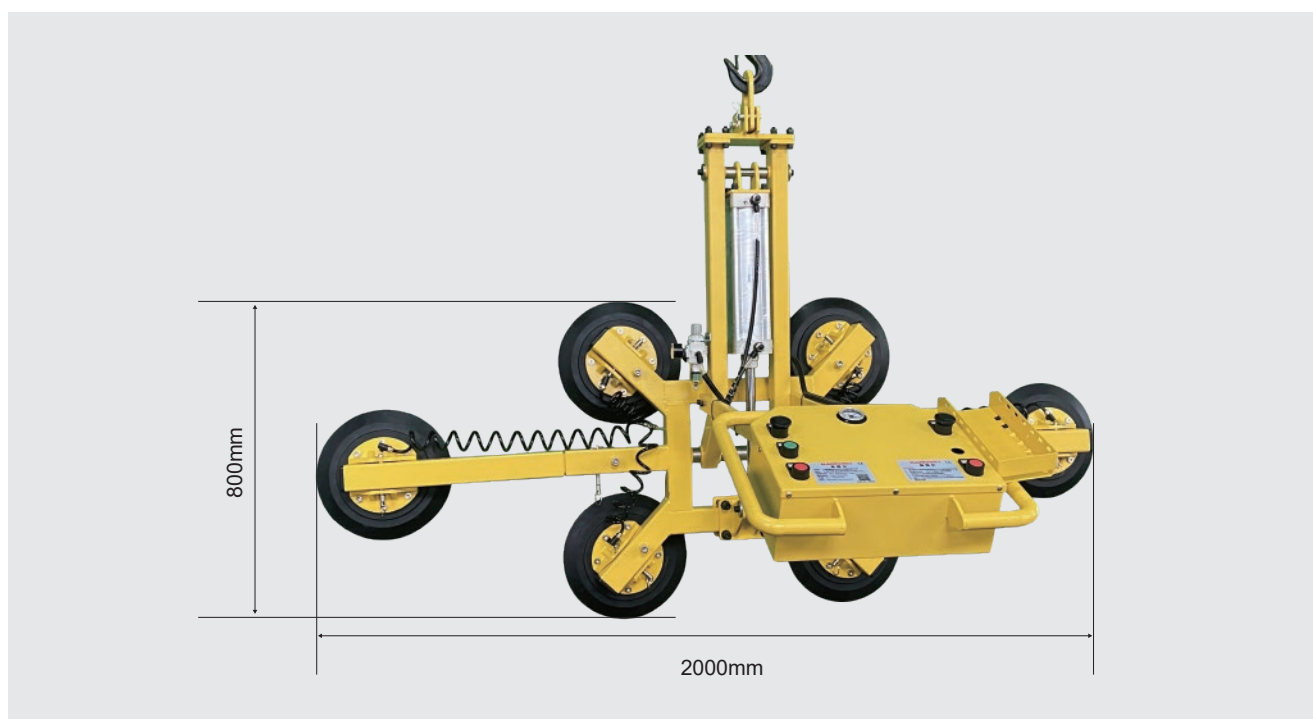

产品名称及型号 Product&Model	安全载重 Safety Loading	外型尺寸(mm) Size	吸盘直径 (mm) Sucker Diameter	吸盘个数 Sucker Number	电源系统 Power System	控制方式 Control Mode	功能 Function
HP-GFX150-2S	150kg	800x300	Ø300	2个	压缩空气 (0.6-0.8Mpa)	手动	气动90度翻转+气动90度旋转 Flip 90 degrees (pneumatic) + rotate 90 degrees (pneumatic)
HP-GFX250-4S	250kg	860x720	Ø300	4个	压缩空气 (0.6-0.8Mpa)	手动	
HP-GFX350-6S	350kg	1800x1200	Ø300	6个	压缩空气 (0.6-0.8Mpa)	手动	
HP-GFQ400-6S	400kg	1800x1200	Ø300	6个	压缩空气 (0.6-0.8Mpa)	手动	
HP-GFD400-6S	400kg	2000x800	Ø300	6个	压缩空气 (0.6-0.8Mpa)	手动	气动90度翻转 Tilting 90 degree (Pneumatic)



打胶机下片-气动升降
气动90度翻转加旋转 HP-GFX150-2S (150KG)



清洗机上下片-气动升降
气动90度翻转加旋转 HP-GFX250-4S (250KG)



玻璃附框搬运-气动升降
气动90度翻转加旋转 HP-GFX350-4S (350KG)



磨边机上下片-气动升降
气动90度翻转加旋转 HP-GFX350-4S (350KG)



夹胶玻璃进釜-气动升降
气动90度翻转 HP-GFQ400-6S (400KG)

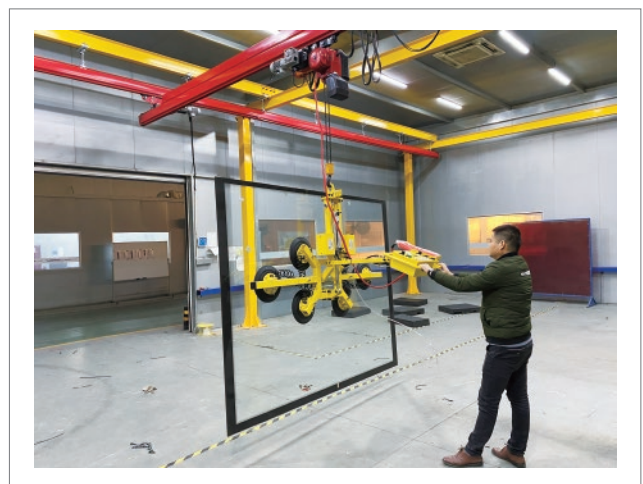

轨道幕墙玻璃搬运-葫芦升降
气动90度翻转 HP-GFD400-6S (400KG)

玻璃深加工大型吸吊设备 HP-GHQ Large-scale of lifting equipment of glass deep processing HP-GHQ

- HP-GHQ系列设备广泛应用于各种大型原片玻璃，大型中空玻璃，大型夹胶玻璃，大型钢化玻璃的吊装
HP-GHQ series equipment is widely used in lifting large scale of sheet glass, hollow glass, laminated glass and tempered glass.
- 该设备采用“H”型框架结构，4倍安全系数，设备整体牢固安全，更加适合大板面玻璃吊装
The equipment adopts "H" frame structure with 4 times safety factor, make the whole equipment is firm and safe, and it is more suitable for lifting large scale of glass.
- 设备自带真空补压系统，可保证玻璃在搬运过程中整个真空系统维持在一个相对恒定的安全压力值
The equipment self contained Vacuum compensating system. It can ensure that the entire vacuum system is maintained at a relatively constant safe pressure value during the glass moving process.
- 数显式真空压力表及电池电量表，能更清楚的随时监测设备安全运转
The digital display vacuum pressure gauge and battery fuel gauge can more clearly monitor the safe operation of equipment at any time.

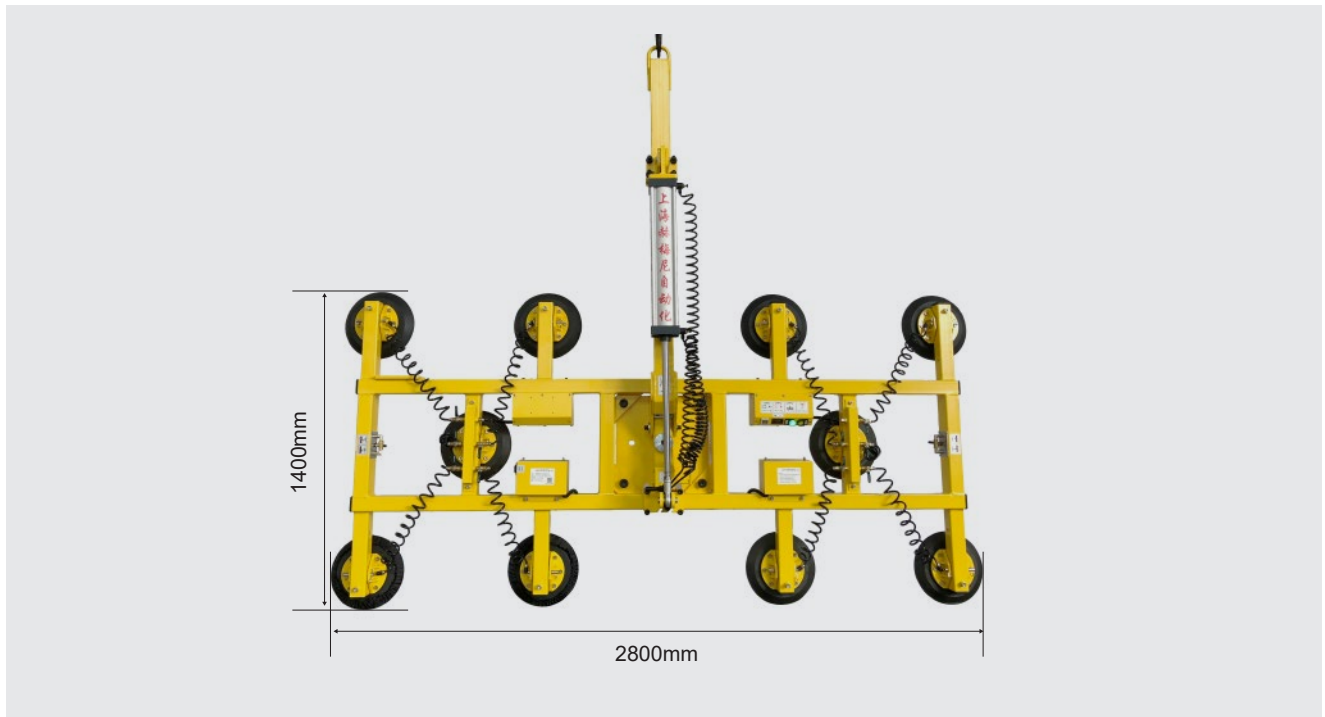

产品名称及型号 Product&Model	安全载重 Safety Loading	外型尺寸(mm) Size	吸盘直径 (mm) Sucker Diameter	吸盘个数 Sucker Number	电源系统 Power System	控制方式 Control Mode	功能 Function
HP-GHQ800-8S	800kg	2800x1400	Ø300	8个	DC12V	手动/遥控	气动90度翻转 Tilting 90 degree (Pneumatic)
HP-GHQ1000-10S	1000kg	2800x1400	Ø300	10个	DC12V	手动/遥控	
HP-GHQ1200-12S	1200kg	2800x1400	Ø300	12个	DC12V	手动/遥控	
HP-GHQ1500-16S	1500kg	(1000+3000+1000)x1400	Ø300	16个	DC12V	手动/遥控	
HP-GHD2000-20S	2000kg	(1500+3600+1500)x1400	Ø300	20个	DC12V/380V	遥控	0-90度电动翻转 0-90 degrees electric retroflexion



钢化玻璃90度气动翻转搬运
直流十二爪吸吊设备 HP-GHQ1200-12S (1200KG)



钢化玻璃90度气动翻转搬运
直流十二爪吸吊设备 HP-GHQ1200-12S (1200KG)



亚克力90度气动翻转搬运
直流十六爪吸吊设备 HP-GHQ1500-16S (1500KG)



原片玻璃90度电动翻转搬运
交流二十爪吸吊设备 HP-GHD2000-20S (2000KG)

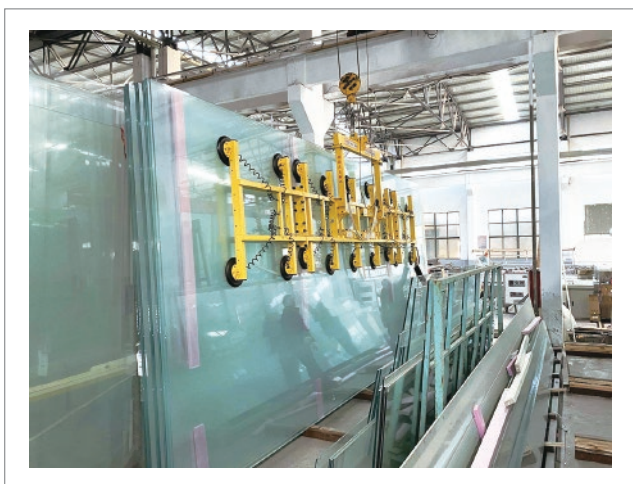

原片玻璃90度手动翻转搬运(双系统)
直流二十爪吸吊设备 HP-GH2000-20S (2000KG)



原片玻璃90度手动翻转搬运(双系统)
直流三十爪吸吊设备 HP-GH3000-30S (3000KG)

弯弧玻璃吸吊设备 HP-GA Arc glass suction crane equipment HP-GA

- 广泛应用于各种弧面玻璃安装与搬运
Widely used in a variety of curved glass installation and handling.
- 采用直流真空泵+直流电池，在使用过程中，无需另外接气源或电源
DC vacuum pump + DC battery are adopted; When using, there is no need to connect other air source or power source.
- 特殊弧面吸盘，带内置弹簧可有效与弯弧玻璃紧密贴合
Special curved sucker, with built-in spring which can effectively fit securely to any curved glass.
- 设备尺寸灵活多变，具备多种组合方式
The size of device is flexible, and can be used with a variety of combinations.

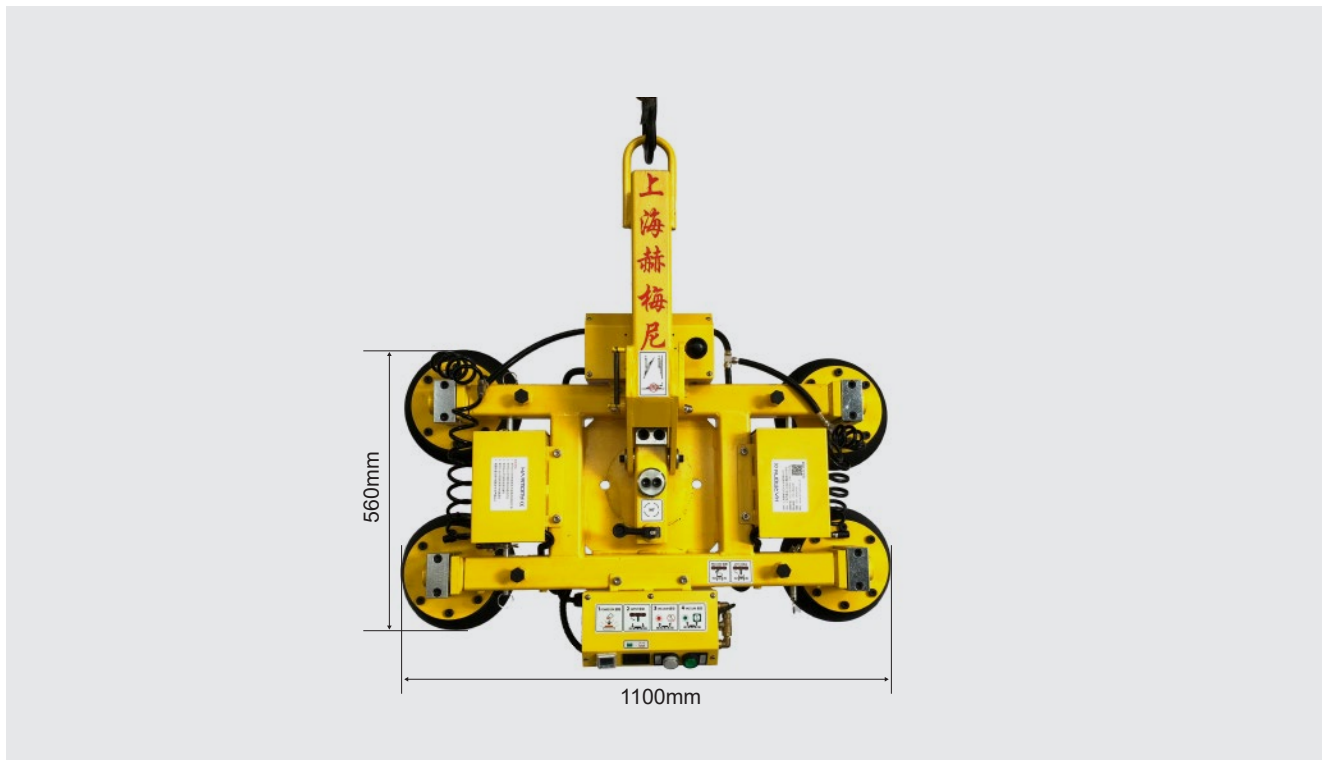

产品名称及型号 Product&Model	安全载重 Safety Loading	外型尺寸(mm) Size	吸盘直径 (mm) Sucker Diameter	吸盘个数 Sucker Number	电源系统 Power System	控制方式 Control Mode	功能 Function
HP-GA200-4S	200kg	1100x560	Ø240	4个	DC12V	手动/遥控	手动360度旋转以及90度翻转 Rotating 360 Degree (Manual) and Tilting 90 degree (Manual)
HP-GA400-8S	400kg	1800x560	Ø240	8个	DC12V	手动/遥控	
HP-GA500-10S	500kg	2400x1200	Ø240	10个	DC12V	手动/遥控	
HP-GA600-12S	600kg	2400x1200	Ø240	12个	DC12V	手动/遥控	可增加气动式翻转附件 Extra Pneumatic Tilting Accessories will be Optional
HP-GA800-14S	800kg	2800x1200	Ø240	14个	DC12V	手动/遥控	
HP-GA1000-20S	1000kg	3200x1200	Ø240	20个	DC12V	手动/遥控	



弯弧玻璃手动翻转旋转搬运
直流十爪吸吊设备 HP-GA500-10S (500KG)



弯弧玻璃手动翻转旋转搬运
直流八爪吸吊设备 HP-GA400-8S (400KG)



弯弧玻璃手动翻转旋转搬运
直流八爪吸吊设备 HP-GA400-8S (400KG)



弯弧玻璃手动翻转旋转搬运
直流二十爪吸吊设备 HP-GA1000-20S (1000KG)



弯弧玻璃手动翻转旋转搬运
直流八爪吸吊设备 HP-GA400-8S (400KG)



弯弧玻璃手动翻转旋转搬运
直流十爪吸吊设备 HP-GA500-10S (500KG)

电动翻转型吸吊设备 HP-DF Electric flip suction crane equipment HP-DF

- 广泛应用于玻璃深加工、铝板加工、板材装配等场合
Widely used in glass processing and manufacturing, aluminium or other metallic plate processing and other occasions.
- 0-90度电动翻转，可在任意位置停止
0-90 degrees electric rotor can be adjusted to any position.
- 吸盘位置可调节以满足不同板材尺寸的变化
Sucker position can be adjusted to meet the different plate sizes and shapes.

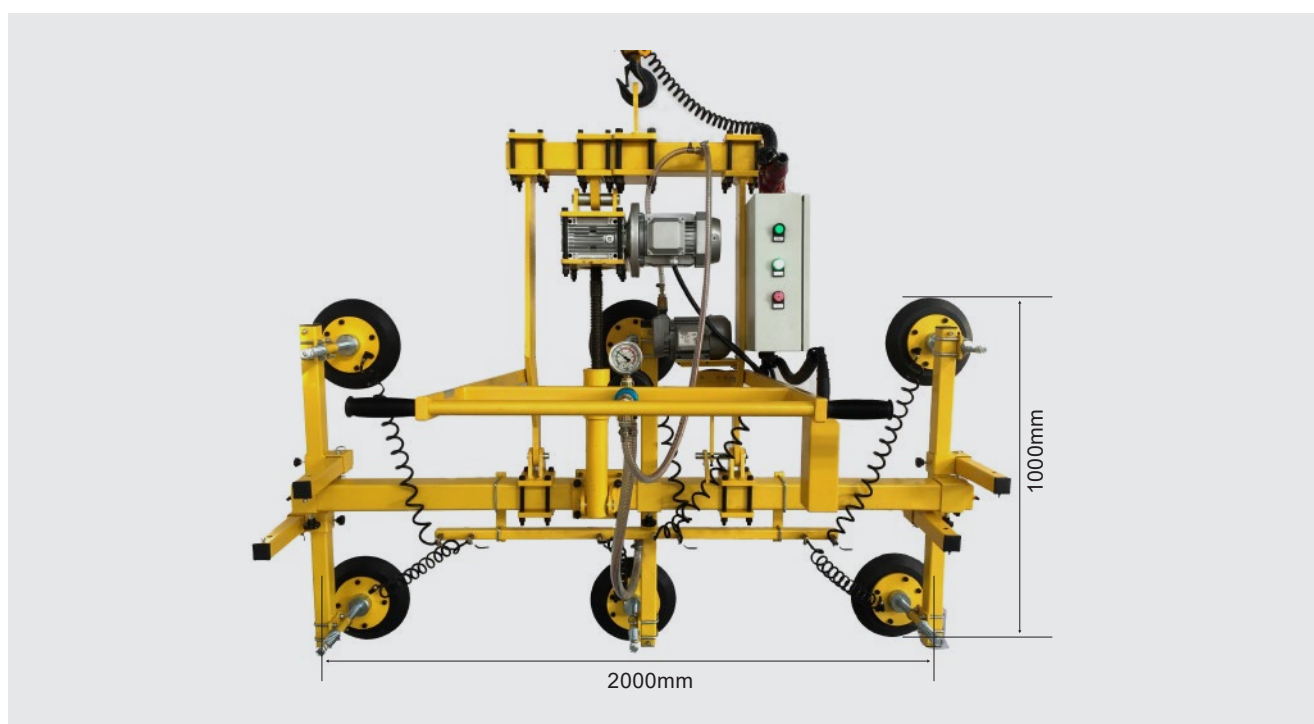

产品名称及型号 Product&Model	安全载重 Safety Loading	外型尺寸(mm) Size	吸盘直径 (mm) Sucker Diameter	吸盘个数 Sucker Number	电源系统 Power System	控制方式 Control Mode	功能 Function
HP-DF400-4S	400kg	2000x1000	Ø300	4个	380V	手动/遥控	0-90度电动翻转 0-90 degrees electric retroflexion
HP-DF600-6S	600kg	2000x1000	Ø300	6个	380V	手动/遥控	
HP-DF800-8S	800kg	2500x1000	Ø300	8个	380V	手动/遥控	
HP-DF1000-10S	1000kg	4500x1000	Ø300	10个	380V	手动/遥控	
HP-DF1200-12S	1200kg	6000x1000	Ø300	12个	380V	手动/遥控	
HP-DF1500-16S	1500kg	8000x1200	Ø300	16个	380V	手动/遥控	
HP-DF2000-20S	2000kg	10000x1500	Ø300	20个	380V	手动/遥控	



房车厢体90度电动翻转搬运
交流四爪吸吊设备 HP-DF400-4S (400KG)



石材板90度电动翻转搬运
交流六爪吸吊设备 HP-DF600-6S (600KG)



房车厢体90度电动翻转搬运
交流六爪吸吊设备 HP-DF600-6S (600KG)



冷藏车厢体90度电动翻转搬运
交流六爪吸吊设备 HP-DF600-6S (600KG)



房车厢体90度电动翻转搬运
交流十爪吸吊设备 HP-DF1000-10S (1000KG)



原片玻璃90度电动翻转搬运
交流二十爪吸吊设备 HP-GHD2000-20S (2000KG)

卷材与定制吸吊设备 HP-CC Coil and customized suction crane equipment HP-CC

- 根据客户要求和现场实际工况，提供最适合客户的非标设备
Based on customers' requirements and practical field working conditions, we provide the best suitable non-standardized equipment for customers.
- 我们不仅提供产品，而且提供合理的方案
We provide not only products, but also reasonable plans.



铝卷90度电动翻转搬运
交流单腔式铝卷吸吊设备 HP-CC200-1S (200KG)



叉车式90度电动翻转搬运
移动式铝卷吸吊设备 HP-CC500-2S (500KG)



铝卷90度电动翻转搬运
交流单腔式铝卷吸吊设备 HP-CC250-1S (250KG)



房车车顶水平搬运
直流无线遥控式吸吊设备 HP-C100-4S (100KG)



不锈钢板水平搬运
气动八爪吸吊设备 HP-BSC300-8S (300KG)



双面夹式垂直搬运
交直流双面夹式吸吊设备 HP-C500-8S (500KG)

玻璃幕墙小型吸吊设备 HP-GI Glass curtain wall small-scale suction crane equipment HP-GI

- 设备小巧轻便操作简单，自重仅55KG携带方便，最大载重500KG，可翻转可旋转
The equipment is small, light and easy to operate. Its weight is only 55KG and it is easy to carry. The maximum load is 500KG. It can be turned and rotated.
- HP-GI系列设备广泛应用于玻璃搬运及玻璃幕墙安装
HP-GI series of equipment are widely used in glass transition and glass curtain wall installation.
- 采用直流真空泵+直流电池，在使用过程中，无需另外接气源或电源
DC vacuum pump + DC battery are adopted; When using, there is no need to connect other air source or power source.
- 数显式真空压力开关及电池电量表，能更清楚的监测设备安全运转
Digital display vacuum pressure switch and battery charge indicator, which can monitor safe operation of equipment more clearly.
- 设备自带真空补压系统，可保证玻璃在搬运过程中整个真空系统维持在一个相对恒定的安全压力值
With vacuum pressure charging system, equipment can ensure the whole vacuum system within a relatively constant safe pressure value during transition.

	产品名称及型号 Product&Model	HP-GI500-1S
	安全载重 Safety Loading	500KG
	外型尺寸(mm) Size	800x400x260
	吸盘直径(mm) Sucker Diameter	800x400
	吸盘个数 Sucker Number	1个
	电源系统 Power System	DC12V
	控制方式 Control Mode	手动/遥控
	功能 Function	手动360度旋转以及90度翻转 Rotating 360 Degree (Manual) and Tilting 90 degree (Manual)



室外单元板块幕墙安装
直流单爪吸吊设备 HP-GI500-1S (500KG)

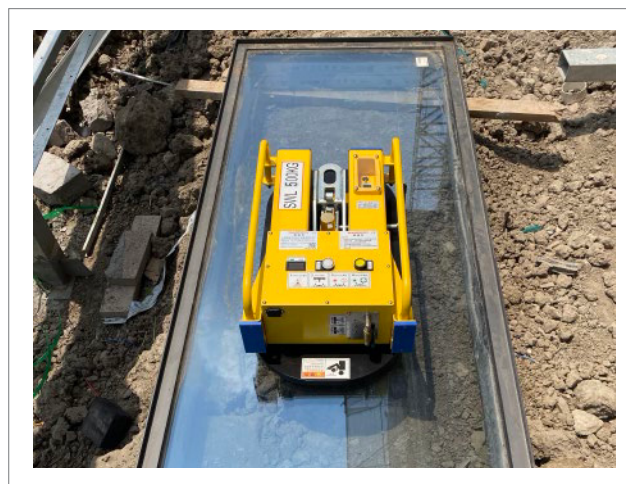

室外单元板块幕墙安装
直流单爪吸吊设备 HP-GI500-1S (500KG)

配套设备（立柱悬臂吊）HP-LZ Supporting equipment (jib crane) HP-LZ

- HP-LZ型立柱悬臂吊是为了适应现代化而产生的新一代轻型吊装设备
HP-LZ type jib crane is a new generation of light lifter supporting equipment to adapt to modernization.
- 配合可靠的电动葫芦，尤其适用于短距离，使用频繁，密集性搬运作业，有效提升工作效率，且占地面积小，易于维修，便于操作等优点
With reliable electric hoist, it is especially suitable for short-distance, frequent use and intensive handling operations, effectively improving work efficiency, and has a small footprint and is easy to maintain, easy to operate and other advantages.

产品名称及型号 Product&Model	额定起重量(KG) Rated Lifting Weight	旋转角度 (°) Rotation Angle	旋转方式(mm) Rotation	旋转半径 (m) Rotation Radius	起升高度 (m) Hoisting Height	控制方式 Control Mode
HP-LZ-250KG	250	270°	手动	1m-6m	1m-5m	手动
HP-LZ-500KG	500	270°	手动	1m-6m	1m-5m	手动
HP-LZ-1000KG	1000	270°	电动	1m-6m	1m-5m	电动



手动行走-手动摆臂(铝型材导轨) HP-LZ-500KG



手动行走-手动摆臂(KBK导轨) HP-LZ-500KG



电动行走-电动摆臂-电动升降(工字钢) HP-LZ-1000KG



电动行走-电动摆臂-电动升降(工字钢) HP-LZ-1000KG

配套设备 (墙壁吊) HP-QB Supporting equipment (jib crane) HP-QB

- HP-QB型墙壁吊是为了适应现代化而产生的新一代轻型吊装设备
HP-QB type jib crane is a new generation of light lifter supporting equipment to adapt to modernization.
- 配合可靠的电动葫芦，尤其适用于短距离，使用频繁，密集性搬运作业，有效提升工作效率，且占地面积小，易于维修，便于操作等优点
With reliable electric hoist, it is especially suitable for short-distance, frequent use and intensive handling operations, effectively improving work efficiency, and has a small footprint and is easy to maintain, easy to operate and other advantages.

产品名称及型号 Product&Model	额定起重量(KG) Rated Lifting Weight	旋转角度 (°) Rotation Angle	旋转方式(mm) Rotation	旋转半径 (m) Rotation Radius	起升高度 (m) Hoisting Height	控制方式 Control Mode
HP-QB-250KG	250	270°	手动	1m-6m	1m-5m	手动
HP-QB-500KG	500	270°	手动	1m-6m	1m-5m	手动
HP-QB-1000KG	1000	270°	电动	1m-6m	1m-5m	电动



手动行走-手动摆臂 (KBK导轨) HP-QB500KG



手动行走-手动摆臂 (KBK导轨) HP-QB500KG



手动行走-手动摆臂 (KBK导轨) HP-QB500KG

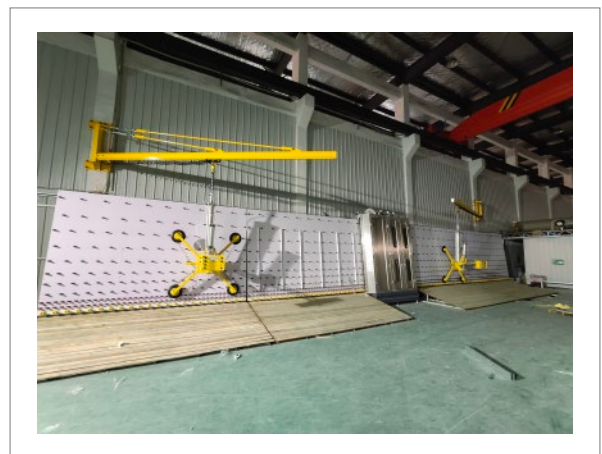

手动行走-手动摆臂 (KBK导轨) HP-QB500KG

配套设备 (桥式导轨) HP-QS Supporting equipment (overhead kbk crane) HP-QS

- 提供各种样式导轨系统
Provide various types of guideway systems.
- 龙门桥式导轨, 导轨长度3-20m, 移动主梁跨度2-9m, 负载50-1000kg
Gantry bridge guideway: the length of guideway is 3-20m; span of moving main beam is 2-9m, load 50-1000kg.
- 吊顶桥式导轨, 利用屋顶的承重梁或加强柱安装, 移动快捷, 惯性小, 不用占地面积, 负载50-1000kg
Ceiling bridge guideway: using the bearing beam of the roof or reinforced column installation, fast movement, small inertia, no need to occupy the ground area, load 50-1000kg.
- 悬臂导轨, 单个立柱安装, 占地面积小, 不影响货物托盘的流转, 最大臂长6m, 负载50-1000kg
Cantilever guideway: single post installation, occupies a small area, and does not affect the circulation of cargo pallets, maximum length 6m, load 50-1000kg.



电动行走-电动升降(KBK导轨)(1000KG)



手动行走-电动升降(KBK导轨+工字钢)(500KG)



电动行走-电动升降(KBK导轨+工字钢)(1000KG)



电动行走-电动升降(KBK导轨)(500KG)



电动行走-电动升降(KBK导轨+工字钢)(500KG)



电动行走-电动升降(KBK导轨+工字钢)(1000KG)

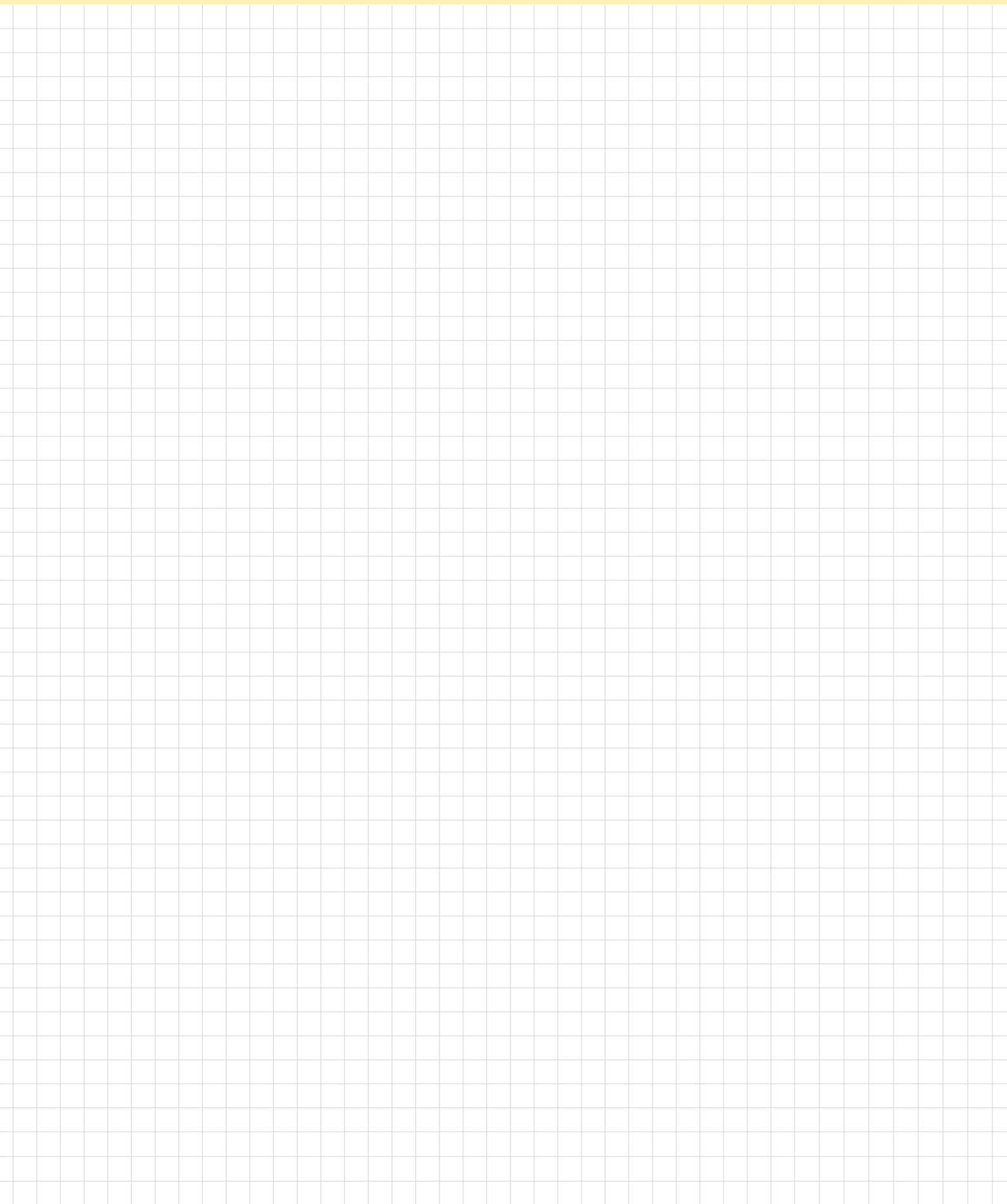

我们的部分用户

our clients (partial)

板材搬运或金属加工企业：

Plate lift or metal processing enterprises:

中航飞机股份有限公司汉中飞机分公司
北京卫星制造厂
江淮汽车股份有限公司
安徽安凯汽车股份有限公司
江铃汽车股份有限公司
中国大唐集团南京环保科技有限公司
山东鲁西化工股份有限公司
江苏大明金属制品有限公司
上海广电电气(集团)股份有限公司
得力集团有限公司
江苏求精集团
南京钢铁股份有限公司
太原太钢大明金属制品有限公司
南宁中车铝材精密加工有限公司
三菱电机上海机电电梯有限公司
蒂森克虏伯航空材料(苏州)有限公司

玻璃幕墙或深加工企业

Glass curtain wall or deep processing enterprises:

沈阳远大铝业工程有限公司
北京江河幕墙股份有限公司
浙江中南幕墙股份有限公司
深圳方大建科集团有限公司
深圳金粤幕墙装饰工程有限公司
苏州金螳螂建筑装饰股份有限公司
武汉凌云建筑装饰工程有限公司
上海美特幕墙有限公司
上海北玻玻璃技术工业有限公司
台玻安徽玻璃有限公司
浙江鲸王玻璃有限公司
上海耀皮玻璃集团股份有限公司
台湾胜达玻璃有限公司
中建幕墙有限公司
五矿瑞和(上海)建设有限公司
无锡恒尚装饰工程有限公司

排名不分先后
In no particular order

从始至终，我们一直在努力满足客户需求。

From the beginning till now, we are always committed to satisfy customers' requirements.

上海赫梅尼自动化设备有限公司

Shanghai Harmony Automation Equipment Co.,Ltd

地址(Address): 上海市青浦工业园区新胜路288号15A幢
15A Building, No. 288, Xincheng Road, Shanghai Qingpu Industrial Zone
电话(TEL): 021-39292435
传真(FAX): 021-39292436
电邮(E-mail): harmony_power@163.com
网站(Web): http://www.sh-harmony.cn



敬请扫描二维码，了解更多详情
Please scan QR code for more information.